



1. Using the Resistor Color Card, Complete the following table

A) For these resistors, determine the nominal, min and max values they should be				B) For these nominal resistor values, find the color bands	
Resistor	Nominal Value	Min Value	Max Value	Nominal Value	List the Resistor Color Bands (R,V,W, etc)
 (Brn-G-Y-Gld)				910 Ω	
 (Y-V-Bk-Gld)				530 KΩ	

2. Complete the breadboard on right so it implements the circuit schematic on left. (Draw wires on board). The triangle symbol is a Light-Emitting-Diode (LED).

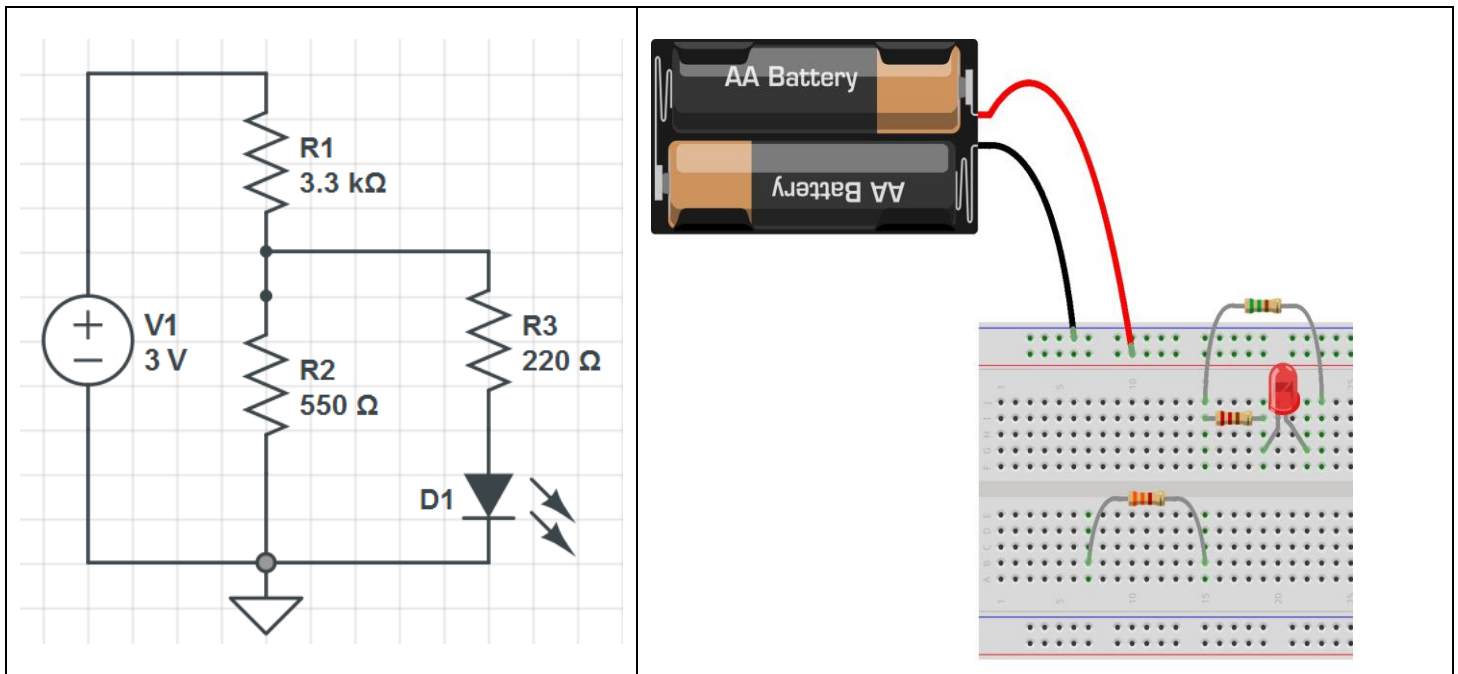

3. Rewire your breadboard from 2 so that a) the circuit still works AND b) you are measuring the current through the LED and the voltage across the 3.3 kΩ Resistor.

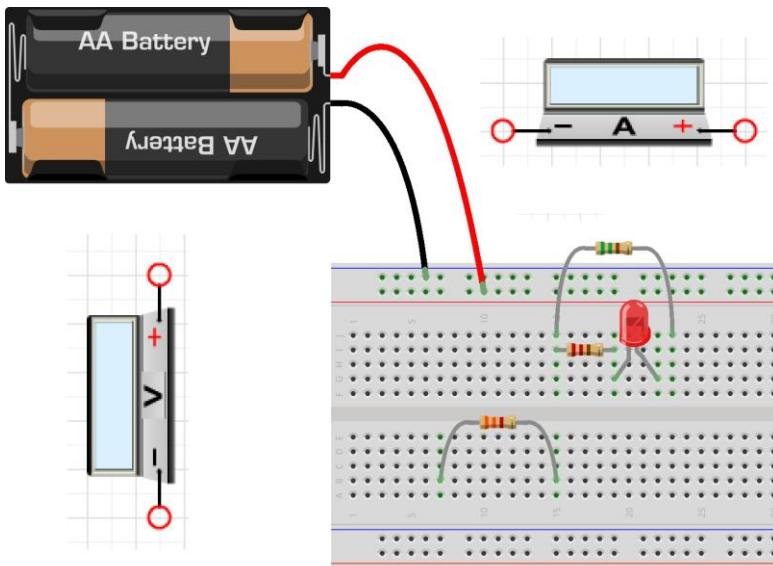

4. Write the commands you would type in FreeMat to solve the following system of equations:

$$3x + 4y + 5z = 32$$

$$21x + 5y + 2z = 20$$

$$x - 2y + 10z = 120$$

5. Write the commands you would type in FreeMat to plot the following measurement data:

$V_s$ (V)	$I_o$ (mA)
4.0	11.1
5.0	12.4
6.0	15.1
8.0	21.8