

ENGR12

Chapter 2.4 – 2.6 Parallel Resistors and Current Dividers

Copyright © The McGraw-Hill Companies, Inc. Permission required for reproduction or display.

Resistors in parallel

Resistors that are connected to the same two points are said to be in parallel.

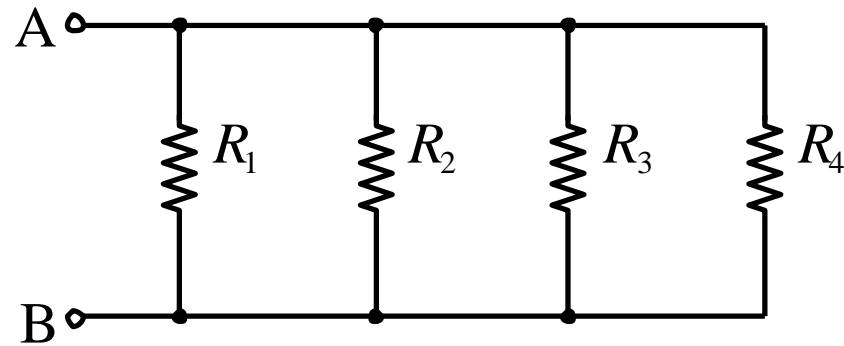

Parallel circuits

A *parallel circuit* is identified by the fact that it has **more than one current path (branch) connected to a common voltage source.**

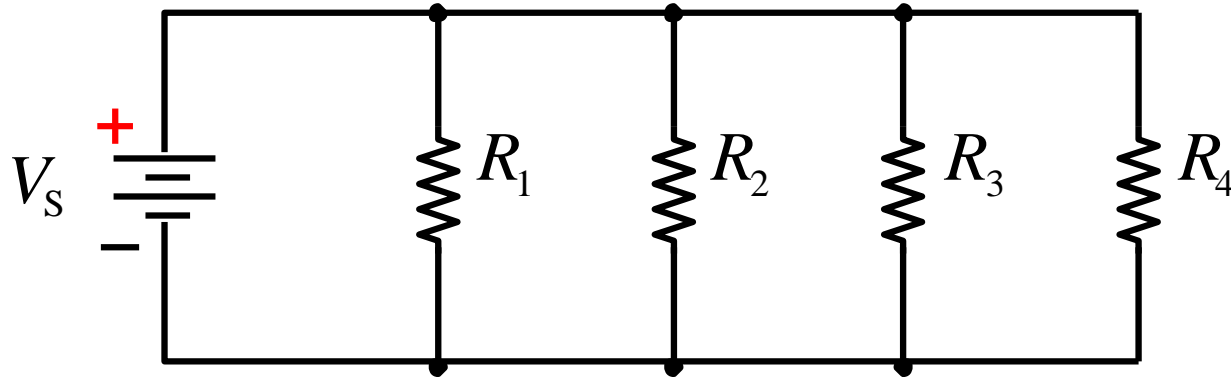

Parallel circuit rule for voltage

Because all components are connected across the same voltage source, the voltage across each is the same.

For example, the source voltage is 5.0 V. What will a voltmeter read if it is placed across each of the resistors?

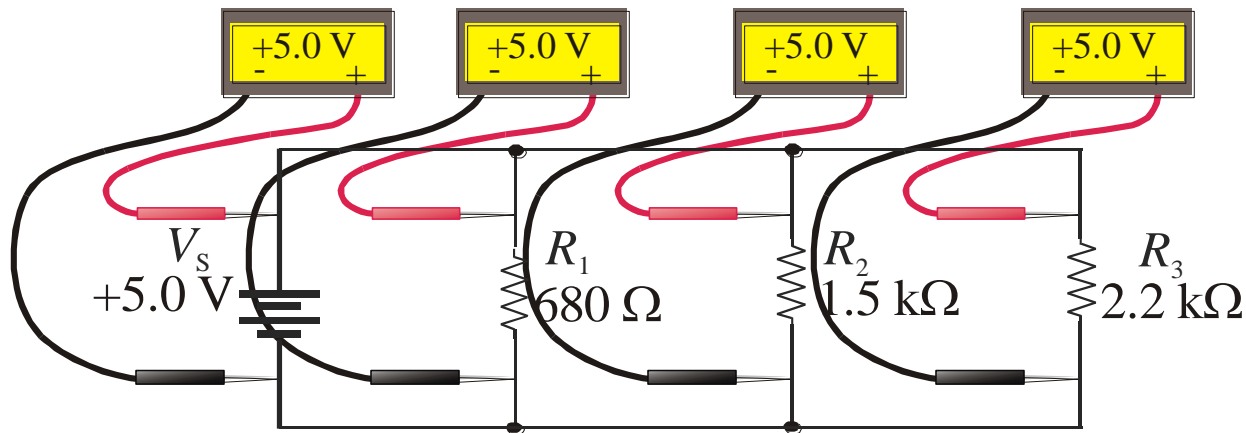

$$R_T = \frac{1}{\frac{1}{R_1} + \frac{1}{R_2} + \frac{1}{R_3}} = \frac{1}{\frac{1}{680} + \frac{1}{1500} + \frac{1}{2200}}$$

Parallel circuit rule for resistance

$$= 386$$

The total resistance of resistors in parallel is the reciprocal of the sum of the reciprocals of the individual resistors.

For example, the resistors in a parallel circuit are 680 Ω , 1.5 k Ω , and 2.2 k Ω . What is the total resistance? 386 Ω

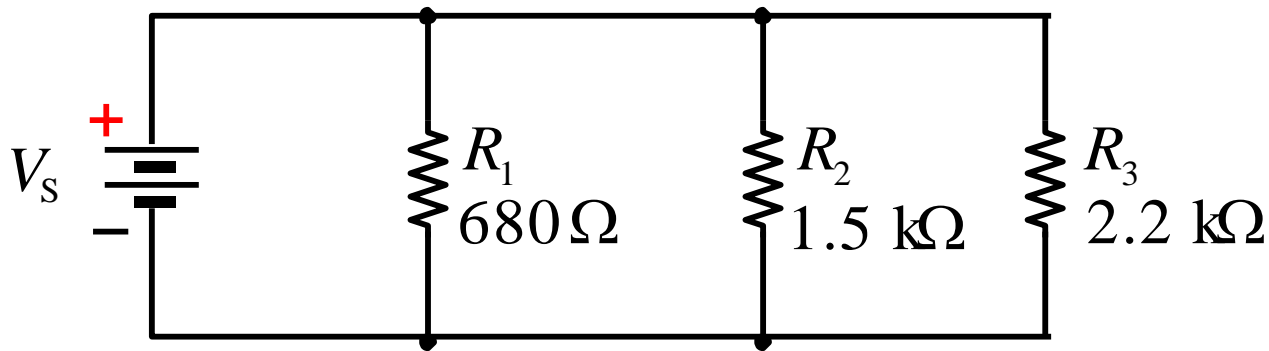

Special case for resistance of two parallel resistors

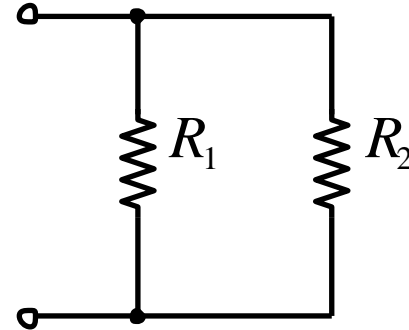

The resistance of two parallel resistors can be found by

either: $R_T = \frac{1}{\frac{1}{R_1} + \frac{1}{R_2}}$ OR $R_T = \frac{R_1 R_2}{R_1 + R_2}$

Question:

What is the total resistance if $R_1 = 27 \text{ k}\Omega$ and

$R_2 = 56 \text{ k}\Omega$? $R_T = \frac{27(56)}{27+56} = 18.2 \text{ k}\Omega$

$$I_n = \frac{V_s}{R_n}$$

Parallel circuit

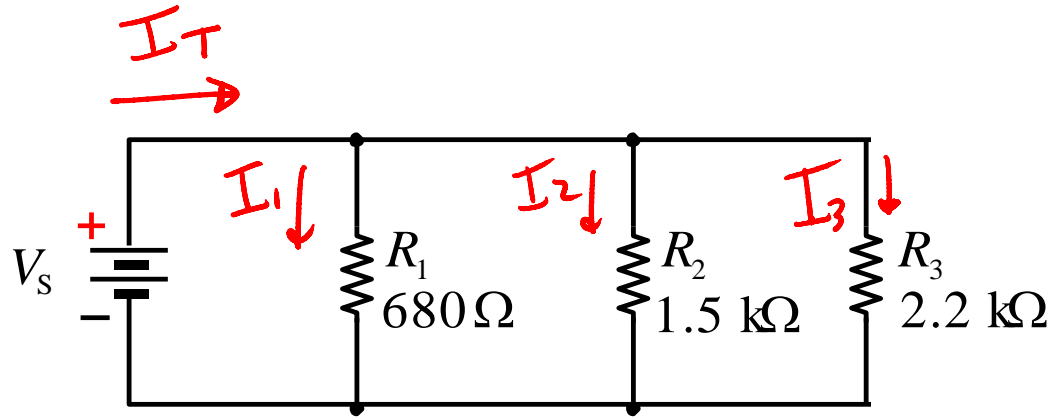

Tabulating current, resistance, voltage and power is a useful way to summarize parameters in a parallel circuit. Continuing with the previous example, complete the parameters listed in the Table.

$I_1 = 7.4 \text{ mA}$	$R_1 = 0.68 \text{ k}\Omega$	$V_1 = 5.0 \text{ V}$	$P_1 = 36.8 \text{ mW}$
$I_2 = 3.3 \text{ mA}$	$R_2 = 1.50 \text{ k}\Omega$	$V_2 = 5.0 \text{ V}$	$P_2 = 16.7 \text{ mW}$
$I_3 = 2.3 \text{ mA}$	$R_3 = 2.20 \text{ k}\Omega$	$V_3 = 5.0 \text{ V}$	$P_3 = 11.4 \text{ mW}$
$I_T = 13.0 \text{ mA}$	$R_T = 386 \Omega$	$V_S = 5.0 \text{ V}$	$P_T = 64.8 \text{ mW}$

Kirchhoff's current law

Kirchhoff's current law (KCL) is generally stated as:

The sum of the currents entering a node is equal to the sum of the currents leaving the node.

Notice in the previous example that the current from the source is equal to the sum of the branch currents.

$I_1 = 7.4 \text{ mA}$	$R_1 = 0.68 \text{ k}\Omega$	$V_1 = 5.0 \text{ V}$	$P_1 = 36.8 \text{ mW}$
$I_2 = 3.3 \text{ mA}$	$R_2 = 1.50 \text{ k}\Omega$	$V_2 = 5.0 \text{ V}$	$P_2 = 16.7 \text{ mW}$
$I_3 = 2.3 \text{ mA}$	$R_3 = 2.20 \text{ k}\Omega$	$V_3 = 5.0 \text{ V}$	$P_3 = 11.4 \text{ mW}$
$I_T = 13.0 \text{ mA}$	$R_T = 386 \text{ }\Omega$	$V_S = 5.0 \text{ V}$	$P_T = 64.8 \text{ mW}$

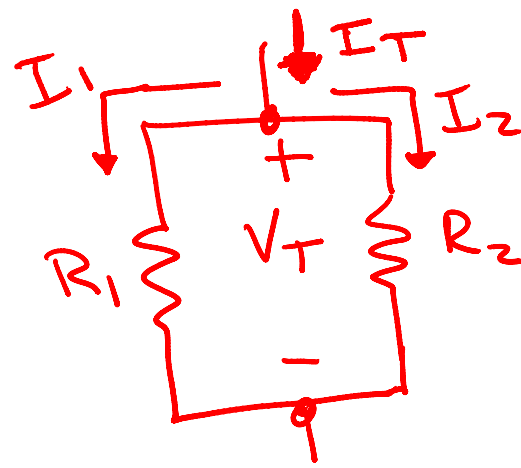

Current divider

When current enters a node (junction) it divides into currents with values that are inversely proportional to the resistance values.

$$I_1 = \frac{V_T}{R_1} = \frac{I_T R_T}{R_1} = \frac{I_T \left(\frac{R_1 R_2}{R_1 + R_2} \right)}{R_1} = I_T \left(\frac{R_2}{R_1 + R_2} \right)$$

Notice the subscripts. The resistor in the numerator is not the same as the one for which current is found.

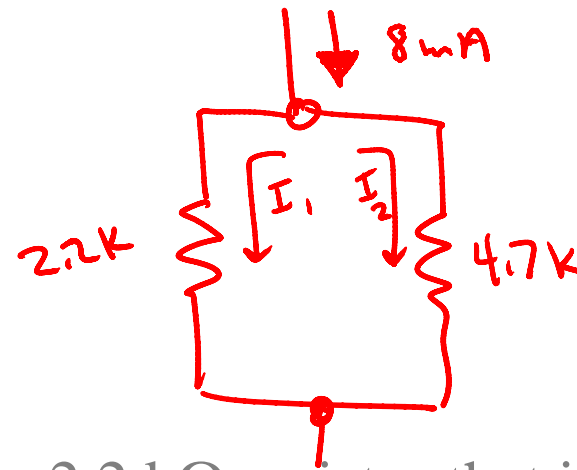

Current divider

Example

Assume that R_1 is a 2.2 k Ω resistor that is in parallel with R_2 , which is 4.7 k Ω . If the total current into the resistors is 8.0 mA, what is the current in each resistor?

Solution

$$I_1 = \left(\frac{R_2}{R_1 + R_2} \right) I_T = \left(\frac{4.7 \text{ k}\Omega}{6.9 \text{ k}\Omega} \right) 8.0 \text{ mA} = 5.45 \text{ mA}$$

$$I_2 = \left(\frac{R_1}{R_1 + R_2} \right) I_T = \left(\frac{2.2 \text{ k}\Omega}{6.9 \text{ k}\Omega} \right) 8.0 \text{ mA} = 2.55 \text{ mA}$$

Notice that the larger resistor has the smaller current.

Power in parallel circuits

Power in each resistor can be calculated with any of the standard power formulas. Most of the time, the voltage is

known, so the equation $P = \frac{V^2}{R}$ is most convenient.

As in the series case, the total power is the sum of the powers dissipated in each resistor.

Question:

What is the total power if 10 V is applied to the parallel combination of $R_1 = 270 \Omega$ and $R_2 = 150 \Omega$? **1.04 W**

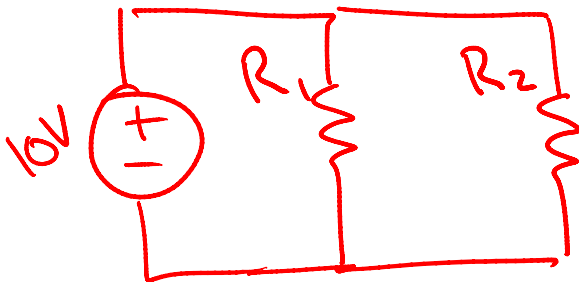

$$P_T = \frac{10^2}{R_1} + \frac{10^2}{R_2} = 1.04 \text{ W}$$

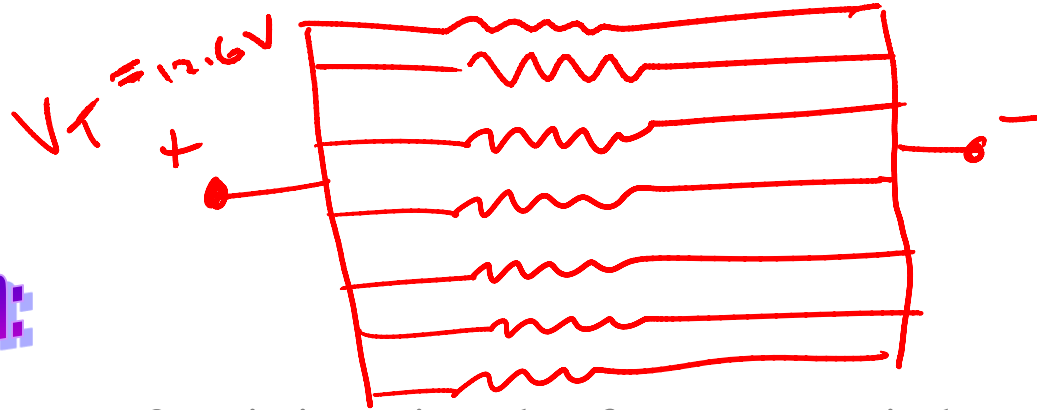

Question:

Assume there are 8 resistive wires that form a rear window defroster for an automobile.

(a) If the defroster dissipates 90 W when connected to a 12.6 V source, what power is dissipated by each resistive wire? $P_T = \sum P_i$

(b) What is the total resistance of the defroster?

$$P_i = \frac{V^2}{R_i}, R_i = \frac{V^2}{P_i}$$

Answer:

(a) Each of the 8 wires will dissipate 1/8 of the total power or $\frac{90 \text{ W}}{8 \text{ wires}} = \underline{11.25 \text{ W}}$

(b) The total resistance is $R = \frac{V^2}{P} = \frac{(12.6 \text{ V})^2}{90 \text{ W}} = 1.76 \Omega$

Follow up:

What is the resistance of each wire? $1.76 \Omega \times 8 = 14.1 \Omega$

Key Terms

Parallel The relationship in electric circuits in which two or more current paths are connected between two separate points (nodes).

Branch One current path in a parallel circuit.

Kirchhoff's current law A law stating the total current into a node equals the total current out of the node.

Node A point or junction in a circuit at which two or more components are connected.

Current divider A parallel circuit in which the currents divide inversely proportional to the parallel branch resistances.

Quiz

1. The total resistance of parallel resistors is equal to
 - a. the sum of the resistances
 - b. the sum of the reciprocals of the resistances
 - c. the sum of the conductances
 - d. none of the above

Quiz

2. The number of nodes in a parallel circuit is

a. one

b. two

c. three

d. any number

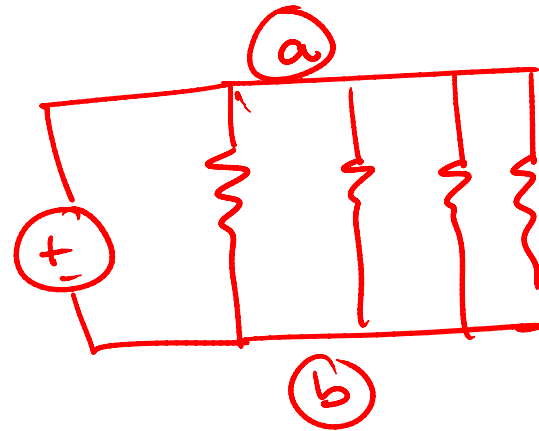

Quiz

3. The total resistance of the parallel resistors is

a. 2.52 k Ω

b. 3.35 k Ω

c. 5.1 k Ω

d. 25.1 k Ω

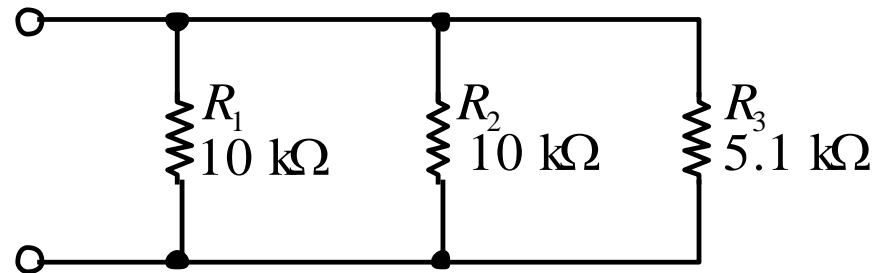

$$R_T = \frac{1}{\frac{1}{10} + \frac{1}{10} + \frac{1}{5.1}} \approx 2.5 \rightarrow \text{(a)}$$

Quiz

$$R_T = \frac{1}{\frac{1}{R} + \frac{1}{R} + \frac{1}{R}} = \frac{1}{\frac{3}{R}} = \frac{R}{3}$$

4. If three equal resistors are in parallel, the total resistance is

- a. one third the value of one resistor.
- b. the same as one resistor.
- c. three times the value of one resistor.
- d. the product of the three resistors

Quiz

5. In any circuit the total current entering a node is
- a. less than the total current leaving the node.
 - b. equal to the total current leaving the node.
 - c. greater than the total current leaving the node.
 - d. can be any of the above, depending on the circuit.

Quiz

6. The current divider formula to find I_1 for the special case of two resistors is

a. $I_1 = \left(\frac{R_1}{R_T} \right) I_T$

b. $I_1 = \left(\frac{R_2}{R_T} \right) I_T$

c. $I_1 = \left(\frac{R_2}{R_1 + R_2} \right) I_T$

d. $I_1 = \left(\frac{R_1}{R_1 + R_2} \right) I_T$

Quiz

7. The total current leaving the source is

a. 1.0 mA

b. 1.2 mA

c. 6.0 mA

d. 7.2 mA

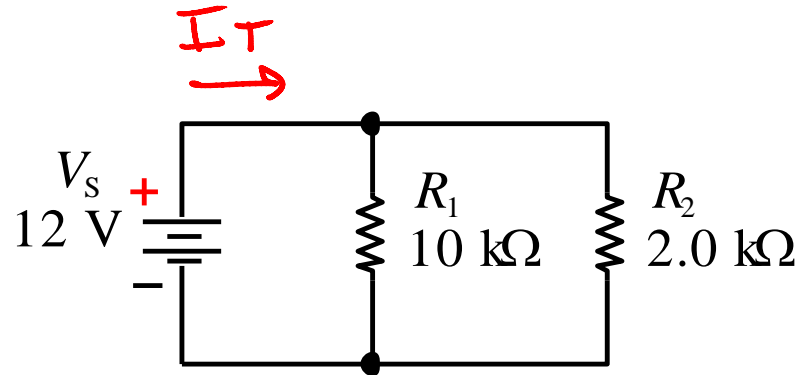

$$I_T = \frac{V}{R_T} = \frac{V}{\frac{R_1 R_2}{R_1 + R_2}} = \frac{12(10+2)}{(10)(2)}$$
$$= 7.2 \text{ mA}$$

Quiz

8. The current in R_1 is

- a. 6.7 mA
- b. 13.3 mA**
- c. 20 mA
- d. 26.7 mA

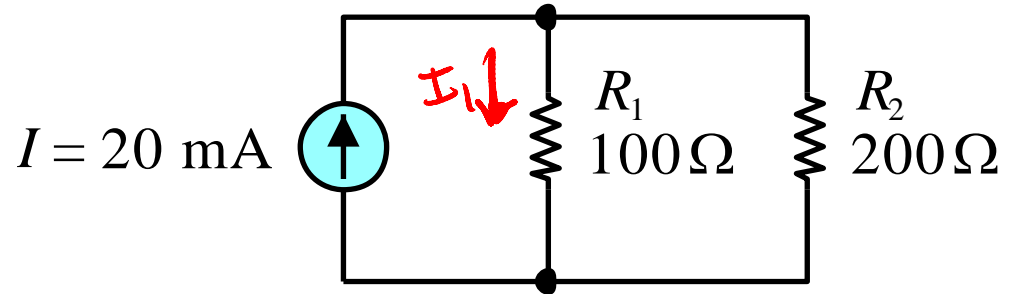

$$I_1 = 20 \left(\frac{R_2}{R_1 + R_2} \right) = 20 \left(\frac{200}{300} \right) \\ = 13.3 \text{ mA}$$

Quiz

9. The voltage across R_2 is

a. 0 V

b. 0.67 V

c. 1.33 V

d. 4.0 V

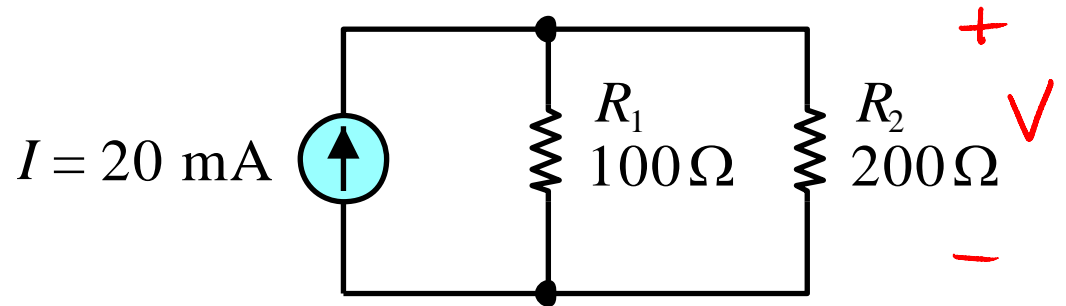

$$\begin{aligned} V &= I R_T = 20 \text{ mA} \left(\frac{100 \cdot 200}{300} \right) \Omega \\ &= 20 (66.6) = 1333 \text{ mV} = \\ &\quad 1.333 \text{ V} \end{aligned}$$

Quiz

10. The total power dissipated in a parallel circuit is equal to the

- a. power in the largest resistor.
- b. power in the smallest resistor.
- c. average of the power in all resistors.
- d. sum of the power in all resistors.

Quiz

Answers:

- | | |
|------|-------|
| 1. d | 6. c |
| 2. b | 7. d |
| 3. a | 8. b |
| 4. a | 9. c |
| 5. b | 10. d |

Handouts

Quiz

3. The total resistance of the parallel resistors is

a. 2.52 k Ω

b. 3.35 k Ω

c. 5.1 k Ω

d. 25.1 k Ω

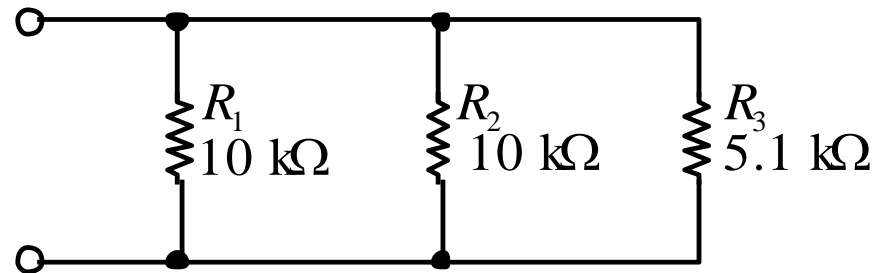

Quiz

7. The total current leaving the source is

- a. 1.0 mA
- b. 1.2 mA
- c. 6.0 mA
- d. 7.2 mA

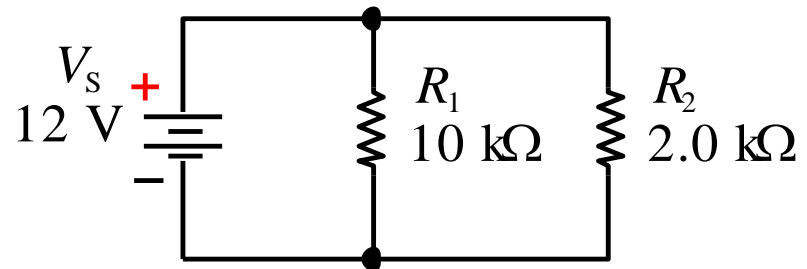

Quiz

8. The current in R_1 is

a. 6.7 mA

b. 13.3 mA

c. 20 mA

d. 26.7 mA

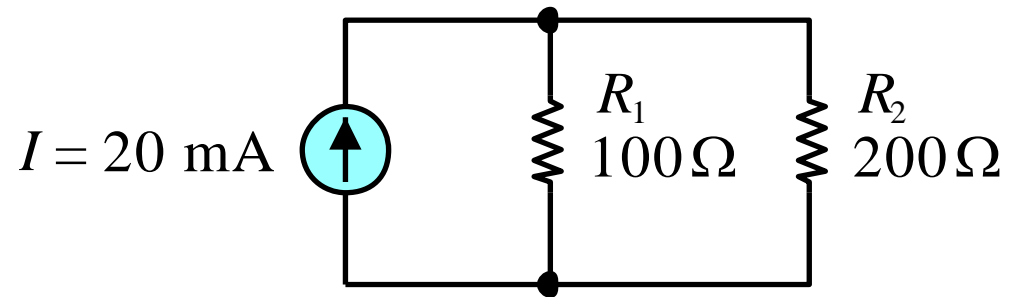

Cleo: Problem 1 Find the current i through the $7\text{k}\Omega$ resistor using current division.

$$I_1 = (10\text{mA}) \left(\frac{2\text{k}}{R_1 + 2\text{k}} \right)$$

$$R_1 = \frac{(10)(3+7)}{10+10} + 3 = 8\text{k}$$

$$I_1 = 10\text{mA} \left(\frac{2}{8+2} \right) = 2\text{mA}$$

$$I = I_1 \left(\frac{10}{10 + R_2} \right) = I_1 \left(\frac{1}{2} \right) = \underline{\underline{1\text{mA}}}$$

